

# Allen Coding Super Compact

Online Hot Foil Coders for the Food, Pharmaceutical, Cosmetic and Chemical industries

The Allen Coding Super Compact Hot Foil Coder, with digital technology, offers highly controllable and unrivaled print accuracy for a consistently high print quality. Its reliable high speed operation reaches speeds of up to 800 prints per minute. The Allen Coding Super Compact Hot Foil Coder offers the best hot foil coding performance available with many advanced features as standard.

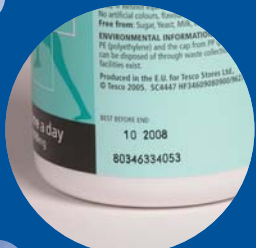

Online hot foil coders are used to code expiry dates, product identification information, lot and batch numbers onto labels and packaged products. With a vast range of frame designs available, it is suitable for installation onto most high speed packaging and labeling machines.

### Quality

The digital display control box gives highly accurate dwell and temperature control ensuring that unrivaled accuracy of print is attained at all times. This also ensures that the foil is used to its maximum efficiency and that the coder is run at its most efficient settings, guaranteeing a quality print.

### Speed

With the advancement of hot foil coding over the years, the Super Compact is capable of printing up to 800 prints per minute.

### Standard features

- Low foil warning, which can be set to individual requirements.
- Foil run-out warning, allowing foil replacement to be immediate, minimising down time. This feature can be connected to the parent machine ensuring no products pass uncoded.
- Low temperature and thermo couple failure warnings inhibits the coder until the correct temperature is reached or fault rectified.
- Variable temperature control to suit the application—set quickly and easily
- Self check diagnostic software
- Left and right hand models are available giving extra installation flexibility.

### Features

- Online coders for packaging and labeling machines
- Digital temperature and dwell control
- High speed operation
- Exceptionally high print quality

## Allen Coding Super Compact Hot Foil Coder

Specifications	
<b>Print Area (maximum)</b>	48 mm x 30 mm (1.89 in x 1.18 in)
<b>Performance Specifications</b>	
Speed (maximum)	800 per minute
<b>Functional Specifications</b>	
Foil Run Out Warning	Standard
Low Temperature Warning	Standard
Diagnostic Software	Standard
Operating Temperature	+70°C to +140°C (+158°F to +284°F); +140°C to +210°C (+284°F to +410°F)
Dwell Time	0.01 - 1.00 seconds
<b>Physical Specifications</b>	
Printhead Size (Max Outside Dimensions)	142 mm x 198 mm x 205 mm (5.60 in x 7.80 in x 8.07 in)
Foil Size	50 mm x 153 m or 305 m (2.00 in x 500 ft or 1000 ft)
Minimum Air Supply	4 bar (60 psi), 16cc per cycle
Electrical Supply	220-240 VAC, 50Hz; 110-120 VAC, 60Hz
Printhead Weight	6.0 kg (13.2 lb)

### Standard Features

- Low foil warning
- Foil run out warning
- Low temperature warning
- Variable temperature control
- Self check diagnostic software

Control Module

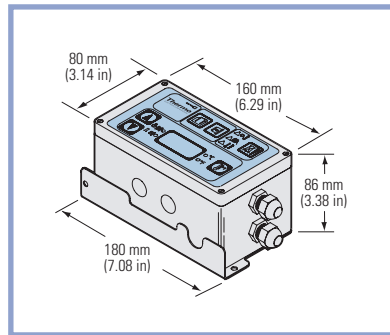

Power Pack

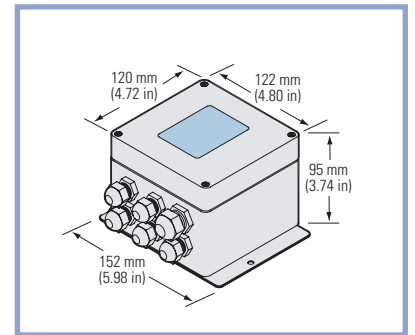

### Allen Coding Super Compact dimensional diagram

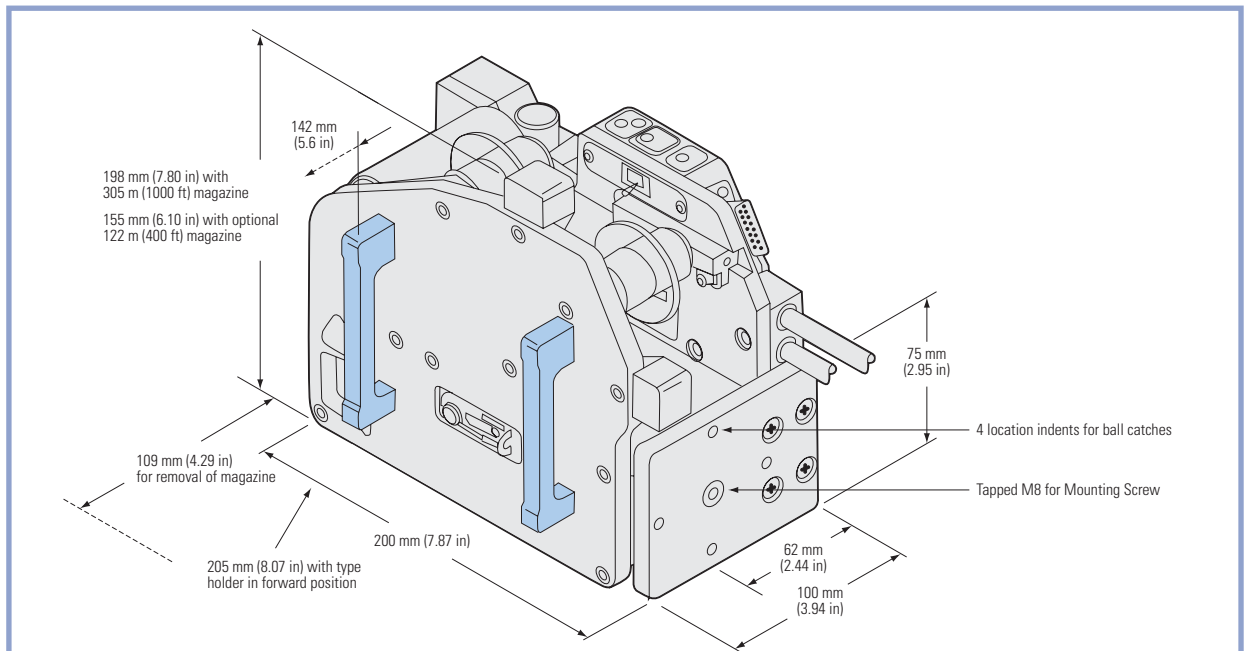

©2006 Allen Coding Systems. Our policy is one of constant improvement, illustrations and specifications cannot be held binding in detail. All rights reserved. Specifications, terms and pricing are subject to change. Please consult your local sales representatives for details.

6 Little Mundells, Welwyn Garden City, Hertfordshire AL7 1LD  
 Telephone: +44(0) 1707 379 500 Fax: +44(0) 1707 320 225  
 email: info@allencoding.co.uk

[www.allencoding.co.uk](http://www.allencoding.co.uk)

